



Body shown with optional equipment

WALK-IN VAN CUSTOMERS

- Delivery Companies
- Baking & Snack Food
- Textile Rental Industry
- Public Utility & Municipalities
- School Districts
- Newspaper Companies
- Contractors & Plumbers

CHASSIS MODEL & SIZES

E350/E450 Stripped Chassis
11', 12', 13', 14', 15', 16', 17' & 18'

STANDARD FEATURES

- Durable long lasting aluminum body
- Extruded aluminum floor with 10" wheel boxes
- Lift up aluminum hood
- Heavy-duty rub rail
- Interior sliding cab doors
- Sliding sash windows on R/L doors
- High-back cloth driver seat with lumbar
- 48,000 BTU Heater/Defroster – with recirculation function
- 8" Deep steel bumper with diamond plate surface
- Exterior dual head mirrors with black finish
- Cab and (1) cargo dome light w/switch on dash
- Incandescent lights recessed in kick plate
- Halogen headlights
- Mud flaps
- Twin 19" rear swing doors
- Aluminum roof
- Undercoating

OPTIONS

- Cab Air Conditioning
- AM/FM Radio
- Aluminum bulkhead with center sliding door
- Door-less driver
- 12-V power source in dash
- Jump Seat – Removable or Bulkhead mounted
- Additional passenger seating
- Power & non-power roof vents
- Additional cab or cargo dome lights
- Exterior LED Lights
- E-Track on cargo walls
- Cargo floor overlays center aisle or full width with .080 aluminum diamond plate
- Rear bumpers with Bustin Grated surface, 8" or 10" deep
- Liftgates
- Multiple cargo packages
- Back-up camera



24" deep aluminum shelves (fixed or bottom folding)



Standard seat with optional armrests



Aluminum bulkhead with center sliding door



Standard cargo area with smooth aluminum plank floor, aluminum roof liner and optional aluminum diamond-plate overlay and bulkhead separating cab and cargo area

DIMENSIONS

| Ford Chassis | | E350** | | E350-E450 | | | | | |
|----------------------------------|-----|------------|------------|------------|------------|------------|------------|------------|------------|
| WB Wheelbase | | 138" | | 158" | | | 176" | | |
| Body Size | BS | 11' | 12' | 13' | 14' | 15' | 16' | 17' | 18'*** |
| Load Space Length | LL | 132" | 144" | 156" | 168" | 180" | 192" | 204" | 216" |
| Cargo Space Length with Bulkhead | | 125.5" | 137.5" | 149.5" | 161.5" | 173.5" | 185.5" | 197.5" | 209.5" |
| Interior Width | IW | 86" or 93" | 86" or 93" | 86" or 93" | 86" or 93" | 86" or 93" | 86" or 93" | 86" or 93" | 86" or 93" |
| Interior Height | IH | 81" or 85" | 81" or 85" | 81" or 85" | 81" or 85" | 81" or 85" | 81" or 85" | 81" or 85" | 81" or 85" |
| Cab to Wheel-Well | CW | 66" | 66" | 86" | 86" | 86" | 104" | 104" | 104" |
| Wheel Box to Rear | WR | 22" | 34" | 26" | 38" | 50" | 44" | 56" | 68" |
| Step Height at Front | SF | 16"-18" | 16"-18" | 16"-18" | 16"-18" | 16"-18" | 16"-18" | 16"-18" | 16"-18" |
| Step Height at Rear | SR | 21"-23" | 21"-23" | 21"-23" | 21"-23" | 21"-23" | 21"-23" | 21"-23" | 21"-23" |
| Overall Length | OL | 224.5" | 236.5" | 248.5" | 260.5" | 272.5" | 284.5" | 296.5" | 308.5" |
| Overall Height (OH)* | 73" | 106"-109" | — | — | — | — | — | — | — |
| | 81" | 114"-117" | 114"-117" | 114"-117" | 114"-117" | 114"-117" | 114"-117" | 114"-117" | 114"-117" |
| | 85" | 118"-122" | 118"-122" | 118"-122" | 118"-122" | 118"-122" | 118"-122" | 118"-122" | 118"-122" |

* Dimension at curb weight **Available 73" High Interior ***18' must have additional leaf springs at rear if E350 is used Please note body dimensions may change from model year to model year.

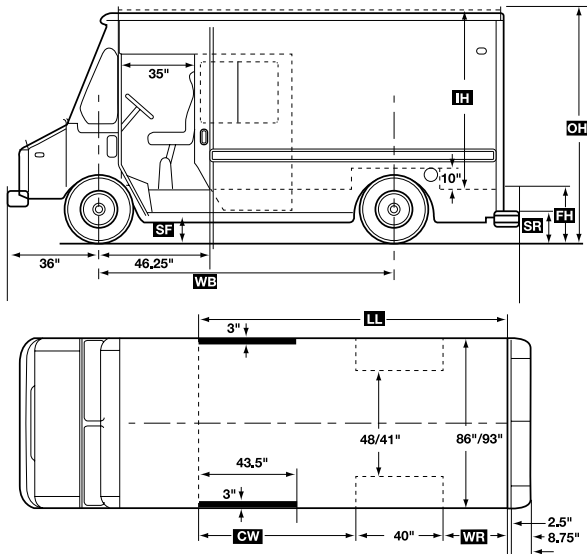

DOORS

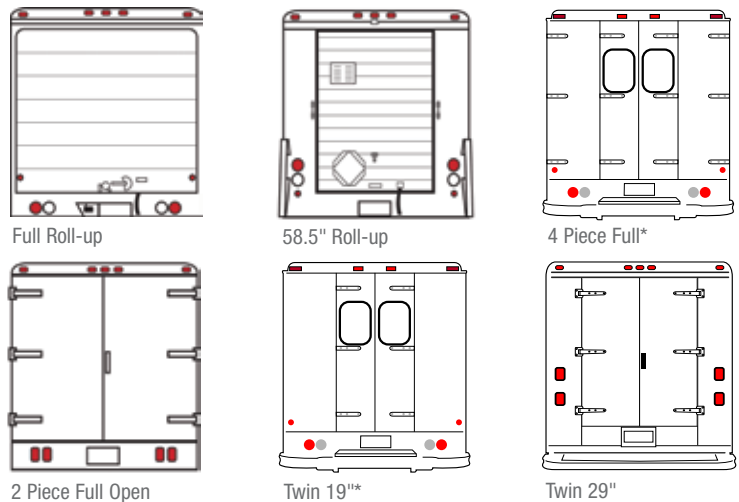

Translucent roof w/30" strip down center aisle or full width



8" or 12" deep aluminum or steel bumper, available with Bustin insert or treadplate



Right side passenger seat



Bulkhead mounted jump seat with optional orange seatbelt



Cargo sidewall liner options

At Morgan Olson, our quest for quality and safety is ongoing and therefore the specifications on the product described herein may vary over time. Please contact us or your local Morgan Olson dealer for the latest product information and available safety features and options.